

# Counteracting ring formation in rotary kilns

DCSE Seminar  
May 15, 2012

## The Problem

**Calcium Aluminate Cements (CAC)** are very white, high purity hydraulic bonding agents providing controlled setting times and strength development for today's high performance *refractory products*.

Used with appropriate refractory aggregates, CAC may be used to make refractory castables having applications in the *steel and other heat-using industries*.



The cement is made by fusing together a mixture of a *calcium-bearing material* (limestone) and an *aluminium-bearing material*.

A typical kiln arrangement:

Reverberatory furnace in which the hot exhaust gases pass upward as the lump raw material mix passes downward.

**In the case of high-alumina refractory cements, where the mix only sinters, a rotary kiln must be used.**



## Rotary Kiln Philosophy

Fundamentally, rotary kilns are heat exchangers in which energy from hot gas phase is extracted by the bed material.

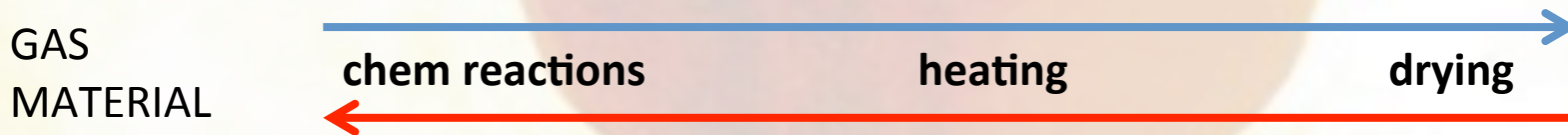

Cylindrical vessel, inclined slightly to the horizontal, which is rotated slowly about its axis.

The material is fed into the upper end of the cylinder. As the kiln rotates, material gradually moves down towards the lower end, and may undergo a certain amount of stirring and mixing.

Hot gases generated by a flame projected from a burner-pipe inside the kiln.

## Rotary Kiln Philosophy

Fundamentally, rotary kilns are heat exchangers in which energy from hot gas phase is extracted by the bed material.

GAS  
MATERIAL

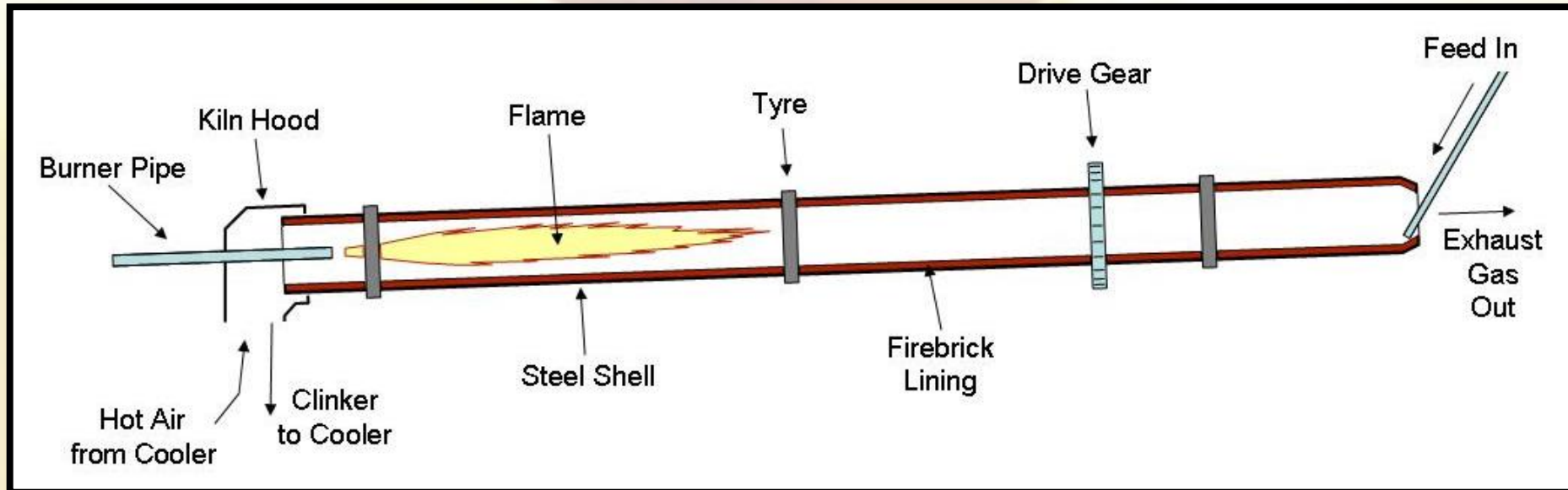

- In 1979 the **Almatis** cement plant (Rotterdam) was built.
- The kiln was designed to produce Calcium Aluminate Cement (CAC).
  - design based only on a *downscaling of typical Portland cement plants*.

- Increasing market demand
- Unscheduled shutdown due to ring formation
- Restrictive emission regulations (NO<sub>x</sub>)
- Future: expand the plant by building a new kiln

Triggered Almatis' management to increase knowledge.

The model is used to:

- ✓ understand in details what happen inside such a 'black-box'
- ✓ help to control the standard production procedure
- ✓ underline critical aspects.



# TURBULENT NON-PREMIXED COMBUSTION IN A ROTARY KILN

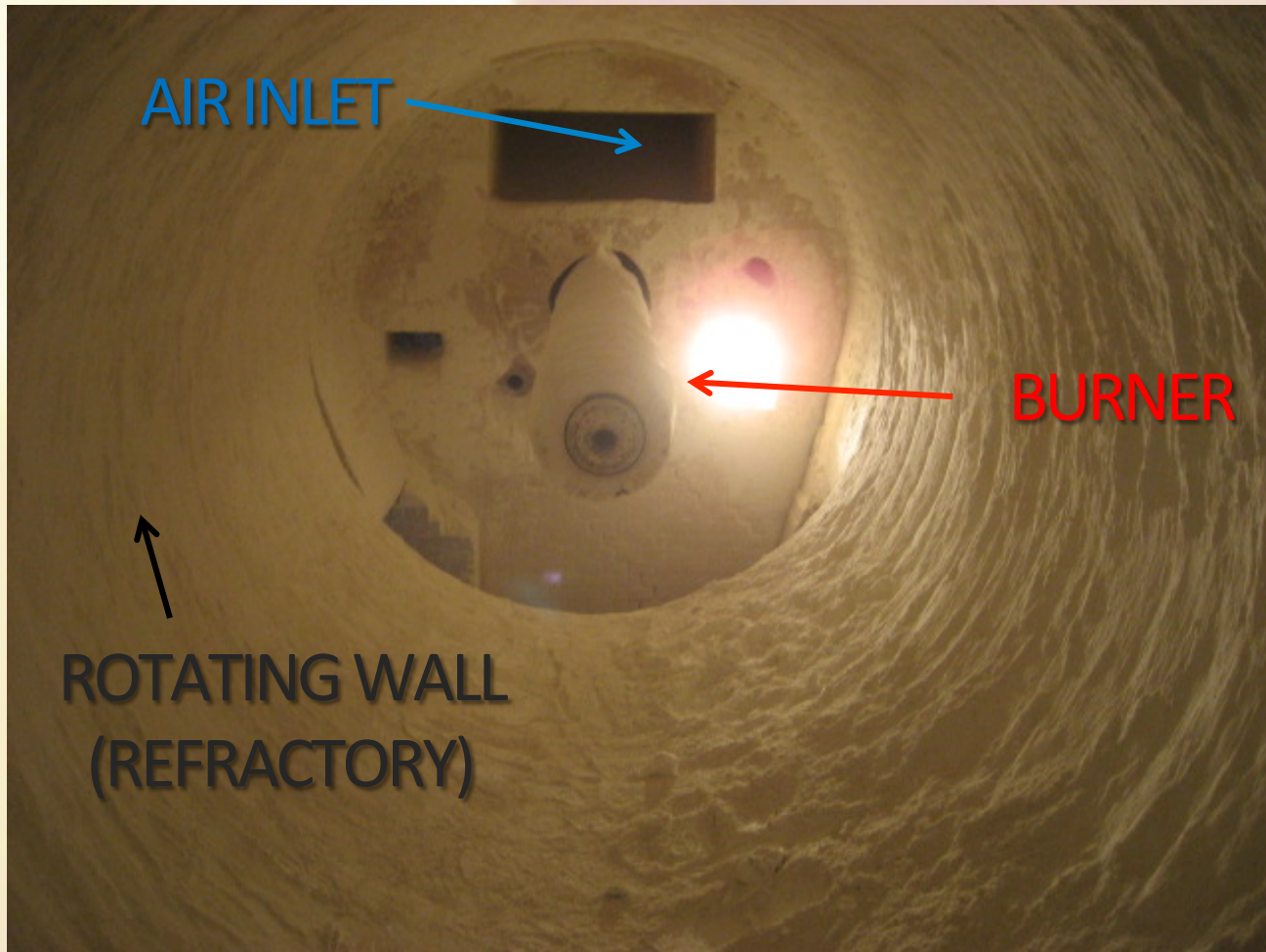

- CONVECTION/CONDUCTION/RADIATION
- NON PREMIXED COMBUSTION
- POLLUTANT EMISSION
- TURBULENCE
- MIXING AND TRANSPORT OF CHEMICAL SPECIES





# TURBULENT NON-PREMIXED COMBUSTION IN A ROTARY KILN

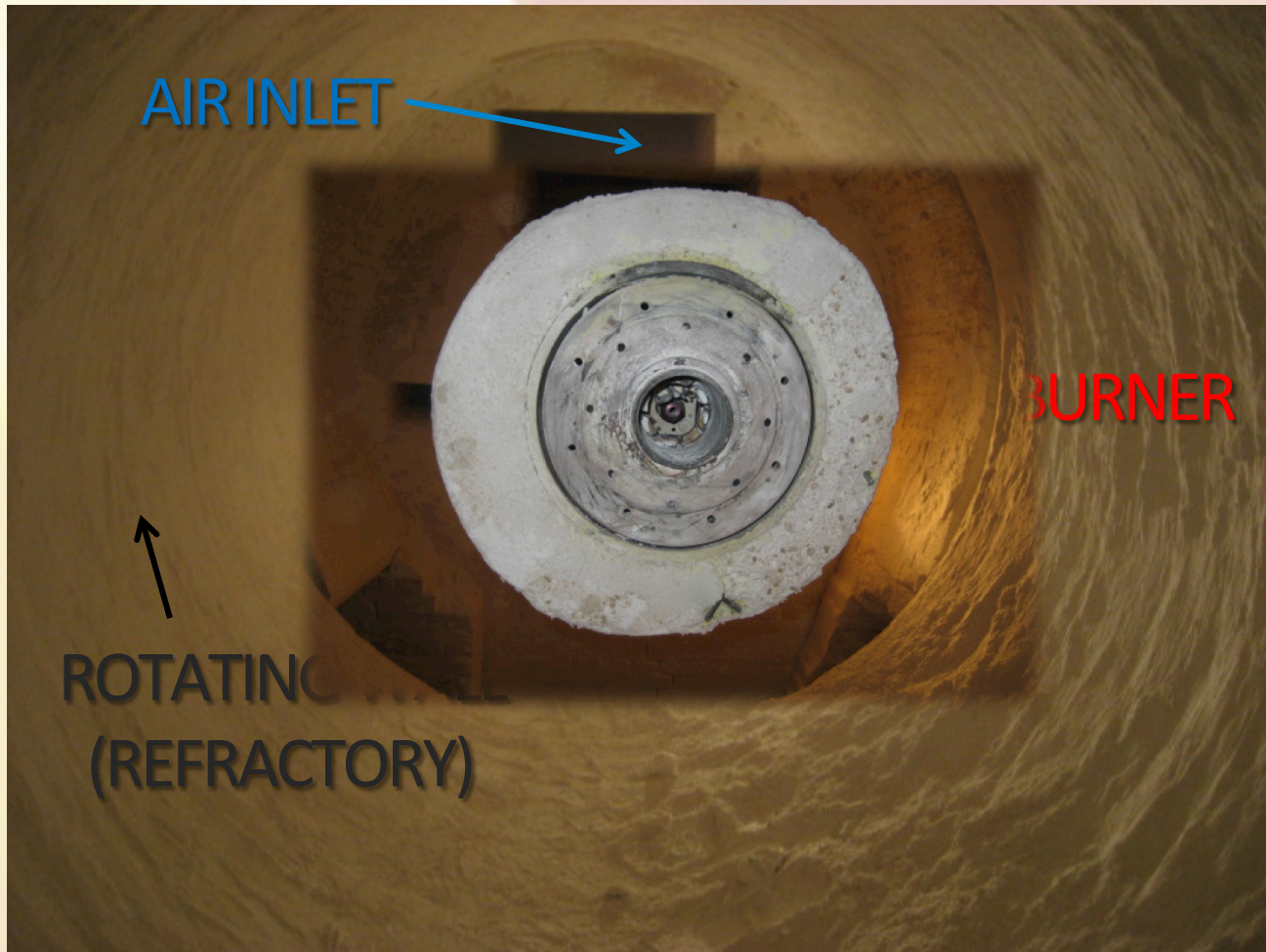

- CONVECTION/CONDUCTION/RADIATION
- NON PREMIXED COMBUSTION
- POLLUTANT EMISSION
- TURBULENCE
- MIXING AND TRANSPORT OF CHEMICAL SPECIES

# TURBULENT NON-PREMIXED COMBUSTION IN A ROTARY KILN

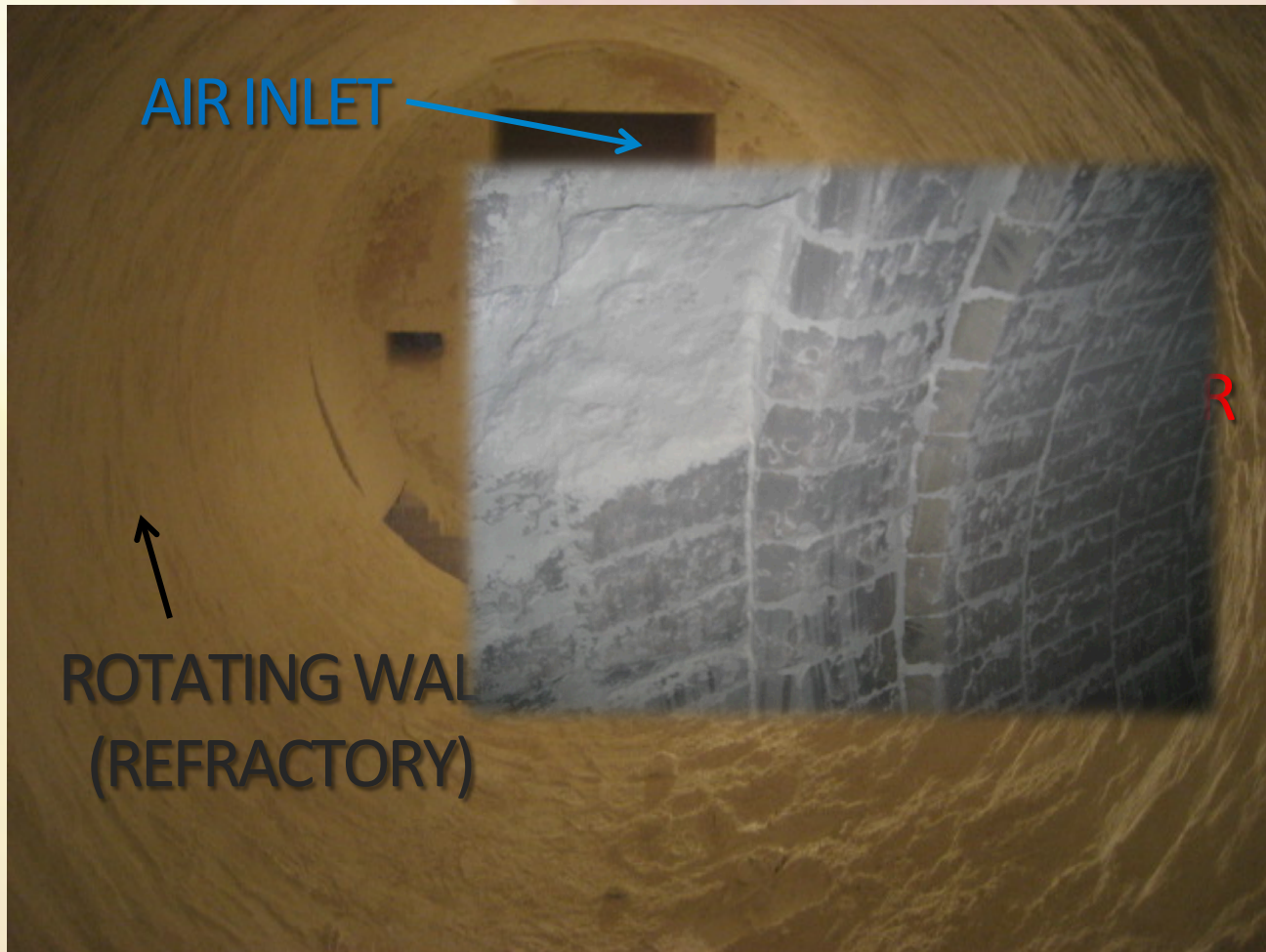

- CONVECTION/CONDUCTION/RADIATION
- NON PREMIXED COMBUSTION
- POLLUTANT EMISSION
- TURBULENCE
- MIXING AND TRANSPORT OF CHEMICAL SPECIES

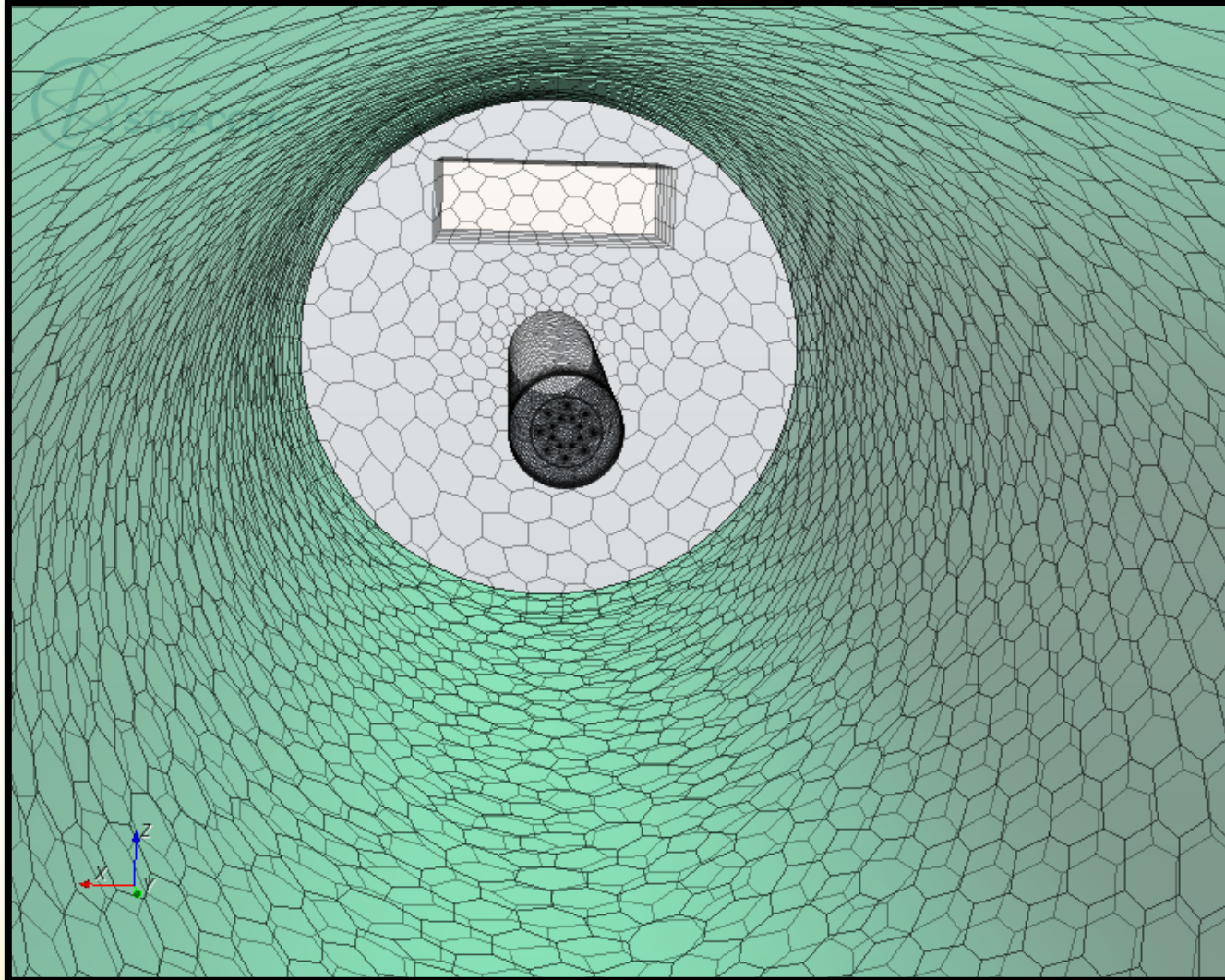

Difficulties in meshing: defining a reasonable distribution of elements  
**kiln length is few thousands order of magnitude longer than the injectors.**  
**Not burden too much the computation** with an high number of elements.

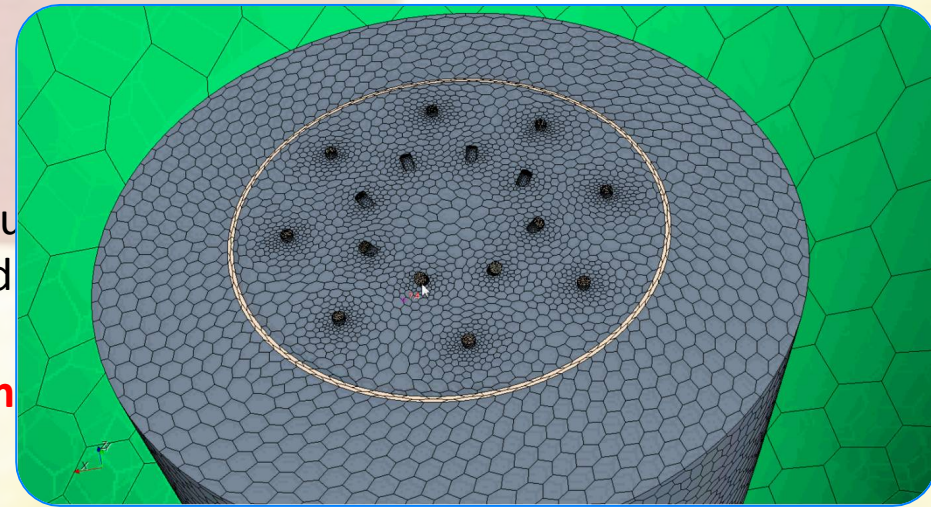
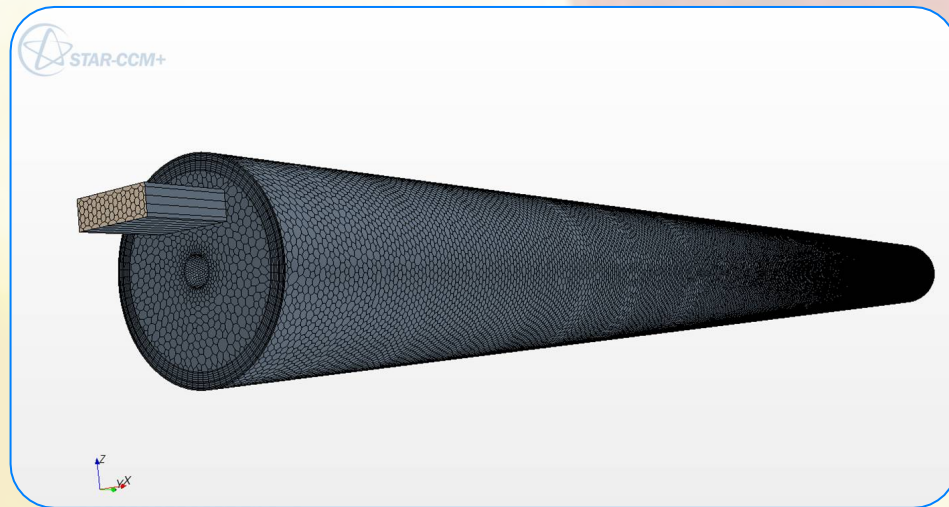

### Polyhedra .

- Same automatic meshing benefits as tetrahedra
- More storage and computing operations per cell, compensated by a higher accuracy.
- Less sensitive to stretching
- 12 faces, 6 optimal directions.

**More accurate solution with a lower cell count.**

Difficulties in meshing:  
kiln length is few thousand  
Not burden too much to

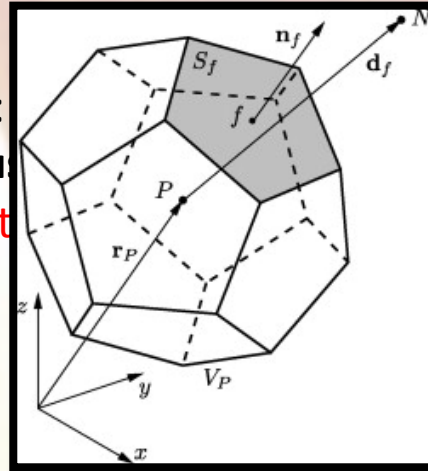

directions  
vectors.  
elements.

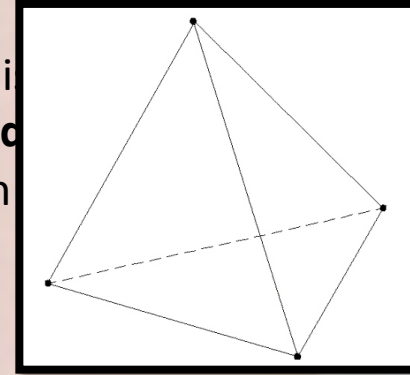

**Tetrahedra** (4 neighbors) are the simplest volume elements:

- faces are plane segment: face and centroid locations are well defined
- cannot be stretched too much

**For a reasonable accuracy a much larger number of control volumes is needed.**

**Polyhedra :**

- Same automatic meshing benefits as tetrahedra
- More storage and computing operations per cell, compensated by a higher accuracy.
- Less sensitive to stretching
- 12 faces, 6 optimal directions.

**More accurate solution with a lower cell count.**

 STAR-CCM+

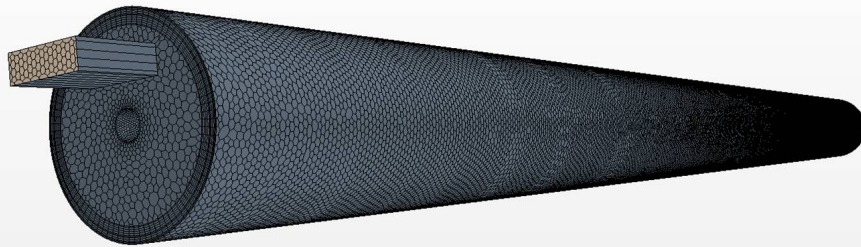

 STAR-CCM+

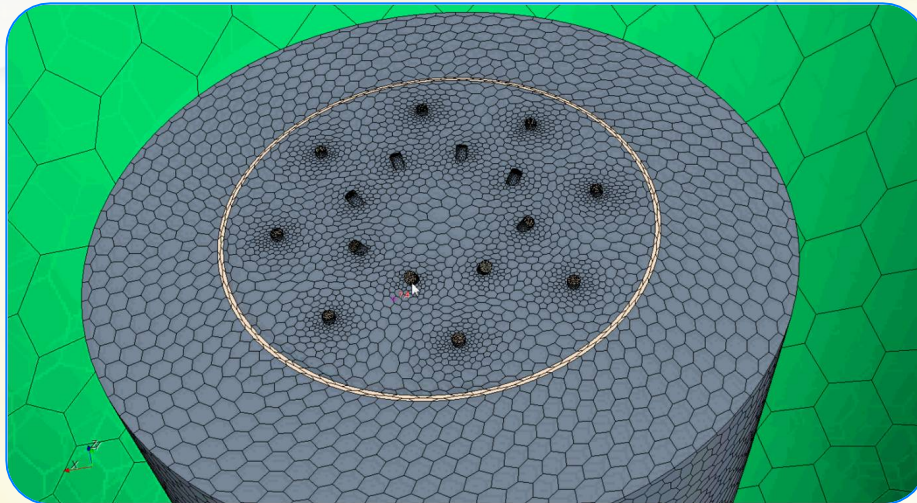
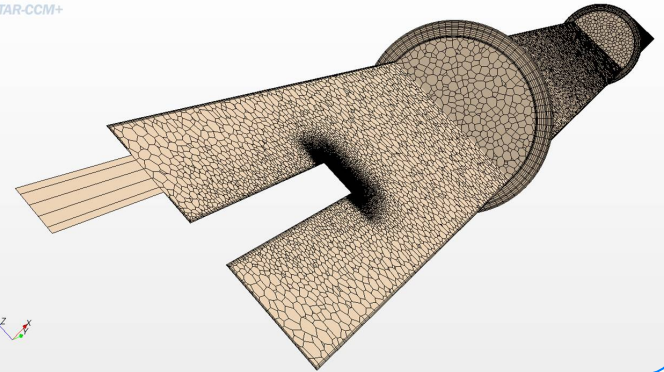

The grid was done using  
polyhedral elements:  
**2.8 Millions of elements**

## NS: Conservation of mass

$$\frac{\partial \rho}{\partial t} + \frac{\partial \rho u_i}{\partial x_i} = 0$$

## NS: Conservation of species

$$\frac{\partial \rho Y_\ell}{\partial t} + \frac{\partial}{\partial x_i} (\rho (u_i + V_{\ell,i}) Y_\ell) = \dot{\omega}_\ell \quad \text{for } \ell = 1 : N$$

## NS: Conservation of momentum

$$\begin{aligned} \frac{\partial}{\partial t} (\rho u_j) + \frac{\partial}{\partial x_i} (\rho u_i u_j) &= -\frac{\partial p}{\partial x_j} + \frac{\partial \tau_{ij}}{\partial x_i} + \rho \sum_{\ell=1}^N Y_\ell f_{\ell,j} \\ &= \frac{\partial \sigma_{ij}}{\partial x} + \rho \sum_{\ell=1}^N Y_\ell f_{\ell,j} \end{aligned}$$

## NS: Conservation of energy

$$\rho \frac{Dh}{Dt} = \frac{Dp}{Dt} - \frac{\partial q_i}{\partial x_i} + \Phi + \dot{Q} + \rho \sum_{\ell=1}^N Y_\ell f_{\ell,j} V_{\ell,i}$$

## RANS: Conservation of mass

$$\frac{\partial \bar{\rho}}{\partial t} + \frac{\partial \bar{\rho} \tilde{u}_i}{\partial x_i} = 0$$

## RANS: Conservation of species

$$\frac{\partial}{\partial t} (\bar{\rho} \tilde{Y}_\ell) + \frac{\partial}{\partial x_i} (\bar{\rho} \tilde{u}_i \tilde{Y}_\ell) = - \frac{\partial}{\partial x_i} \left( \overline{V_{\ell,i} Y_\ell} + \overline{\bar{\rho} u_i'' Y_\ell''} \right) + \bar{\omega}_\ell$$

*for*  $\ell = 1 : N$

## RANS: Conservation of momentum

$$\frac{\partial}{\partial t} (\bar{\rho} \tilde{u}_j) + \frac{\partial}{\partial x_i} (\bar{\rho} \tilde{u}_i \tilde{u}_j) + \frac{\partial \bar{p}}{\partial x_j} = \frac{\partial}{\partial x_i} \left( \overline{\tau_{ij}} - \overline{\bar{\rho} u_i'' u_j''} \right)$$

## RANS: Conservation of energy

$$\frac{\partial}{\partial t} (\bar{\rho} \tilde{h}_s) + \frac{\partial}{\partial x_i} (\bar{\rho} \tilde{u}_i \tilde{h}_s) = \dot{\omega}_T + \frac{Dp}{Dt} + \frac{\partial}{\partial x_i} \left( \overline{\lambda \frac{\partial T}{\partial x_i}} - \overline{\bar{\rho} u_i'' h_s''} \right)$$

$$+ \bar{\Phi} - \frac{\partial}{\partial x_i} \left( \overline{\rho \sum_{k=1}^N h_{s,k} Y_k V_{k,i}} \right)$$



# THE MODEL

## Realizable k-epsilon model

1 Reynolds stress tensor

$$\tilde{R}_{ij} = \widetilde{u_i'' u_j''}$$

$$\frac{\partial}{\partial t}(\rho k) + \frac{\partial}{\partial x_i}(\rho k u_i) = \frac{\partial}{\partial x_j} \left[ \left( \mu + \frac{\mu_t}{\sigma_k} \right) \frac{\partial k}{\partial x_j} \right] + P_k + P_b - \rho \varepsilon - Y_M + S_k$$

$$\frac{\partial}{\partial t}(\rho \varepsilon) + \frac{\partial}{\partial x_i}(\rho \varepsilon u_i) = \frac{\partial}{\partial x_j} \left[ \left( \mu + \frac{\mu_t}{\sigma_\varepsilon} \right) \frac{\partial \varepsilon}{\partial x_j} \right] + C_{1\varepsilon} \frac{\varepsilon}{k} (P_k + C_{3\varepsilon} P_b) - C_{2\varepsilon} \rho \frac{\varepsilon^2}{k} + S_\varepsilon$$

2 Turbulent scalar flux

$$\tilde{F}_{ij} = \widetilde{\phi_k'' u_j''}$$

$$-\rho \widetilde{\phi_k'' u_j''} = \frac{\mu_t}{\sigma_\phi} \frac{\partial \tilde{\phi}_k}{\partial x_j}$$

Eddy diffusivity model

3 Mean source term

$$\bar{\rho} \tilde{S}_k$$

$$S_i = M_i \sum_{j=1}^{n_r} v_{ij} R_j$$

Eddy Break-Up Model (EBU)

$$R_F = -\frac{\rho}{M_F} \left( \frac{1}{\tau_R} \right) A_{ebu} \min \left[ \bar{Y}_F, \frac{\bar{Y}_O}{s_O}, B_{ebu} \left( \frac{\bar{Y}_{P1}}{s_{P1}} + \dots + \frac{\bar{Y}_{Pj}}{s_{Pj}} \right) \right]$$

- Track individual mean **species concentrations** on the grid through **transport equations**.
- The **reaction rates** are calculated as functions of :
  - mean species concentrations,
  - turbulence characteristics
  - temperature.

# THE MODEL

## Realizable k-epsilon model

1 Reynolds stress tensor

$$\tilde{R}_{ij} = \widetilde{u_i'' u_j''}$$

$$\frac{\partial}{\partial t}(\rho k) + \frac{\partial}{\partial x_i}(\rho k u_i) = \frac{\partial}{\partial x_j} \left[ \left( \mu + \frac{\mu_t}{\sigma_k} \right) \frac{\partial k}{\partial x_j} \right] + P_k + P_b - \rho \varepsilon - Y_M + S_k$$

$$\frac{\partial}{\partial t}(\rho \varepsilon) + \frac{\partial}{\partial x_i}(\rho \varepsilon u_i) = \frac{\partial}{\partial x_j} \left[ \left( \mu + \frac{\mu_t}{\sigma_\varepsilon} \right) \frac{\partial \varepsilon}{\partial x_j} \right] + C_{1\varepsilon} \frac{\varepsilon}{k} (P_k + C_{3\varepsilon} P_b) - C_{2\varepsilon} \rho \frac{\varepsilon^2}{k} + S_\varepsilon$$

2 Turbulent scalar flux

$$\tilde{F}_{ij} = \widetilde{\phi_k'' u_j''}$$

$$-\rho \widetilde{\phi_k'' u_j''} = \frac{\mu_t}{\sigma_\phi} \frac{\partial \tilde{\phi}_k}{\partial x_j}$$

Eddy diffusivity model

3 Mean source term

$$\bar{\rho} \tilde{S}_k$$

$$S_i = M_i \sum_{j=1}^{n_r} v_{ij} R_j$$

Eddy Break-Up Model (EBU)

$$R_F = -\frac{\rho}{M_F} \left( \frac{1}{\tau_R} \right) A_{ebu} \min \left[ \bar{Y}_F, \frac{\bar{Y}_O}{s_O}, B_{ebu} \left( \frac{\bar{Y}_{P1}}{s_{P1}} + \dots + \frac{\bar{Y}_{Pj}}{s_{Pj}} \right) \right]$$

+ Radiation: Participating Media Radiation Model (DOF)

+ NOx: Zeldovich Model



# RESULTS: STD\_CONFIG

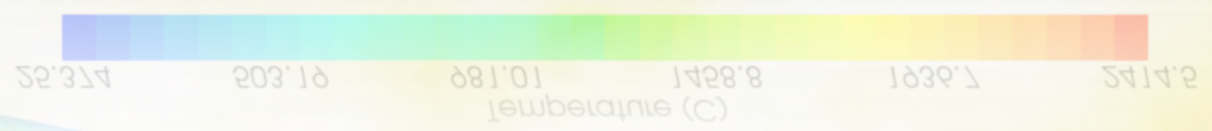
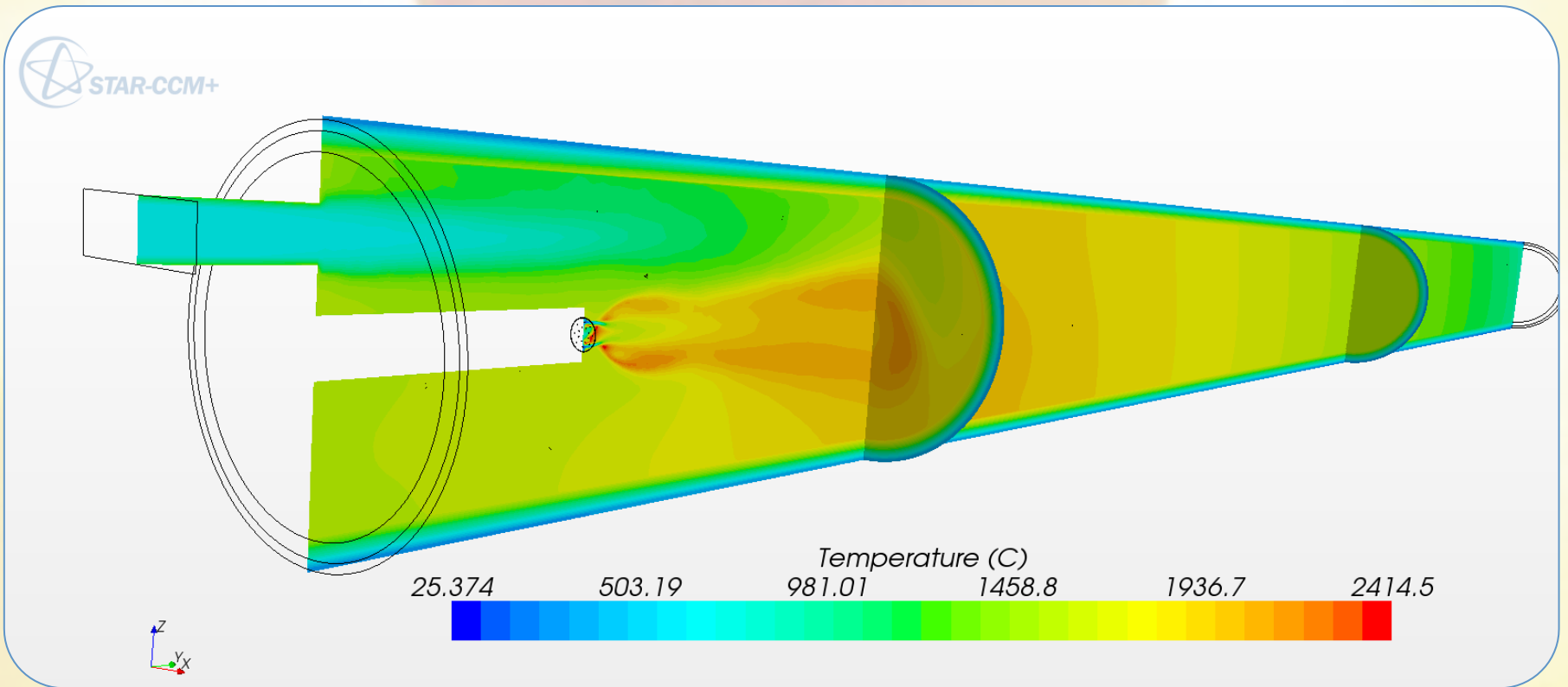

# THE FLAME

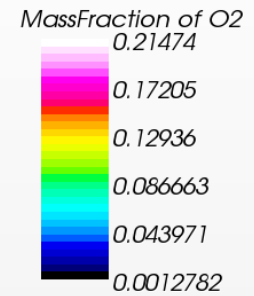
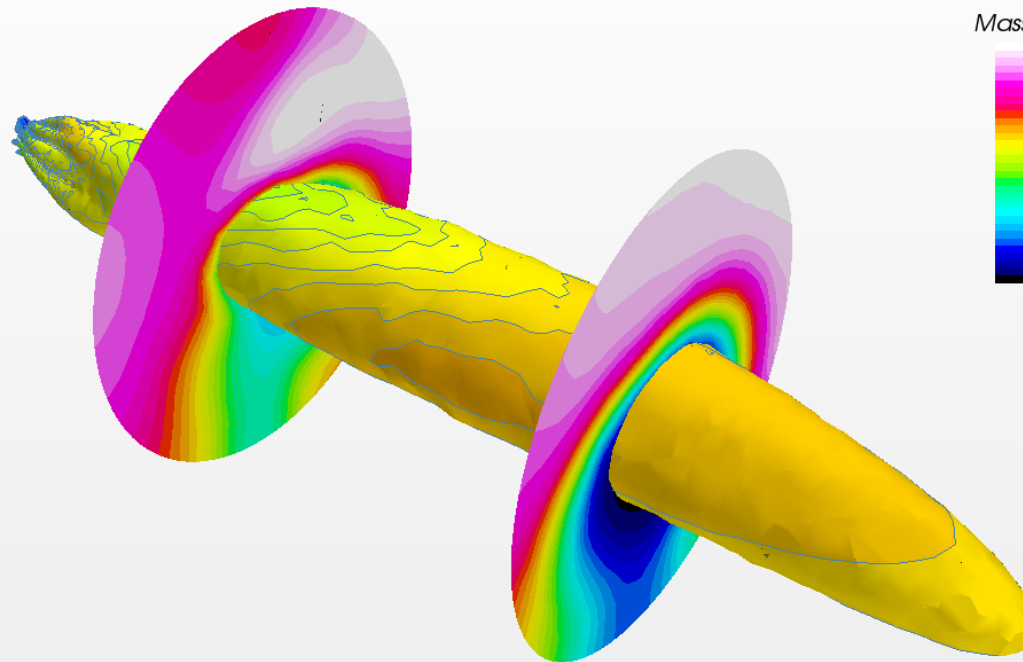
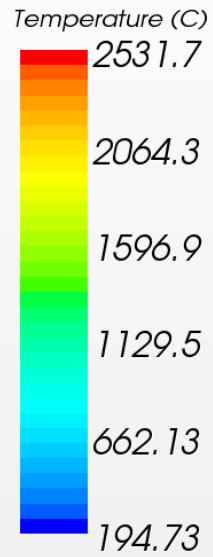

## PROBLEM: RING FORMATION

- **Thin layer of dust** forms in the surface of the refractory lining.
    - Some zones particularly prone to **particle accumulation**.
      - ❖ Summation of particular **thermal and flow conditions** result in the formation of cylindrical deposits, or '**rings**'.
  - In our CAC kiln in Rotterdam: **Front-end / Mid-kiln rings** (located close to the burner).
    - Presumably caused by the **high temperature** in this area, particularly when the refractory **surface is overheated by direct impingement of the burner flame**.
      - ❖ Most troublesome type of ring. Cannot be reached from outside the kiln and is therefore **impossible to remove while the kiln is in operation**.
- ☐ Cause **unscheduled shutdown of the kiln** in less than a month. Depending on the severity of the problem, maintenance labour, make-up lime purchase, and lime mud disposal can bring the cost of a ring outage to **150,000 € per shout down**.

## PROBLEM: RING FORMATION

- **Thin layer of dust** forms on the inner surface of the kiln
  - Some zones particularly affected
    - ❖ Summation of cylindrical rings (due to the formation of a thin layer of dust on the inner surface of the kiln, particularly when the burner flame is outside the kiln and is not visible).
- In our CAC kiln in Rotterdam
  - Presumably caused by the refractory **surface**
    - ❖ Most troublesome therefore in the burner flame.

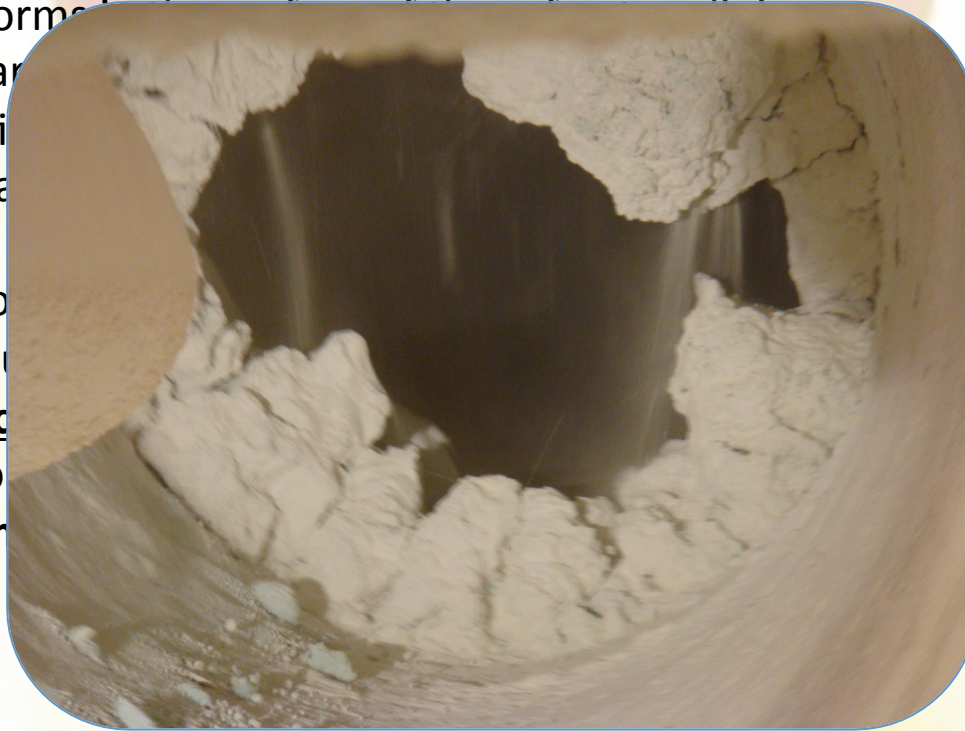

- ❑ Cause **unscheduled shutdown of the kiln** in less than a month. Depending on the severity of the problem, maintenance labour, make-up lime purchase, and lime mud disposal can bring the cost of a ring outage to **150,000 € per shout down**.

# PROBLEM 1: RING FORMATION

Gas-Solid interface Temperature (top) and Incident radiation (bottom)

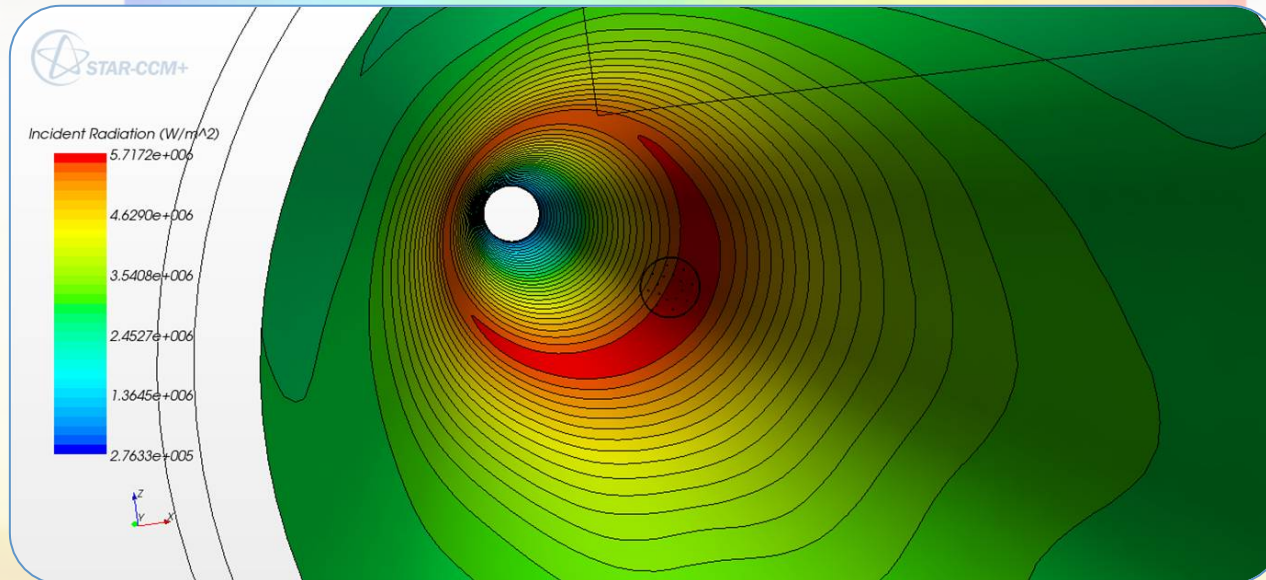
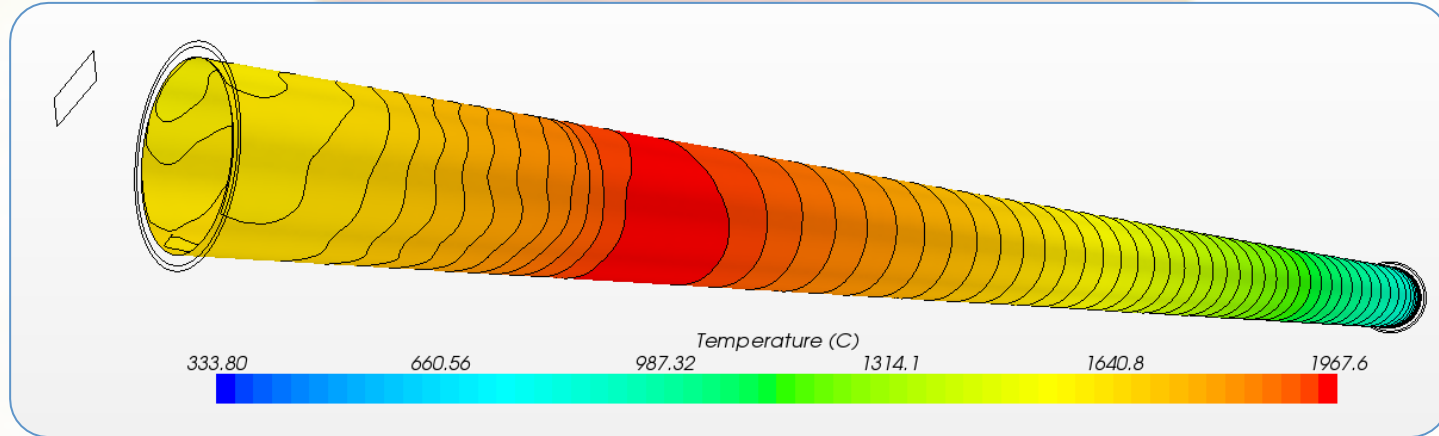



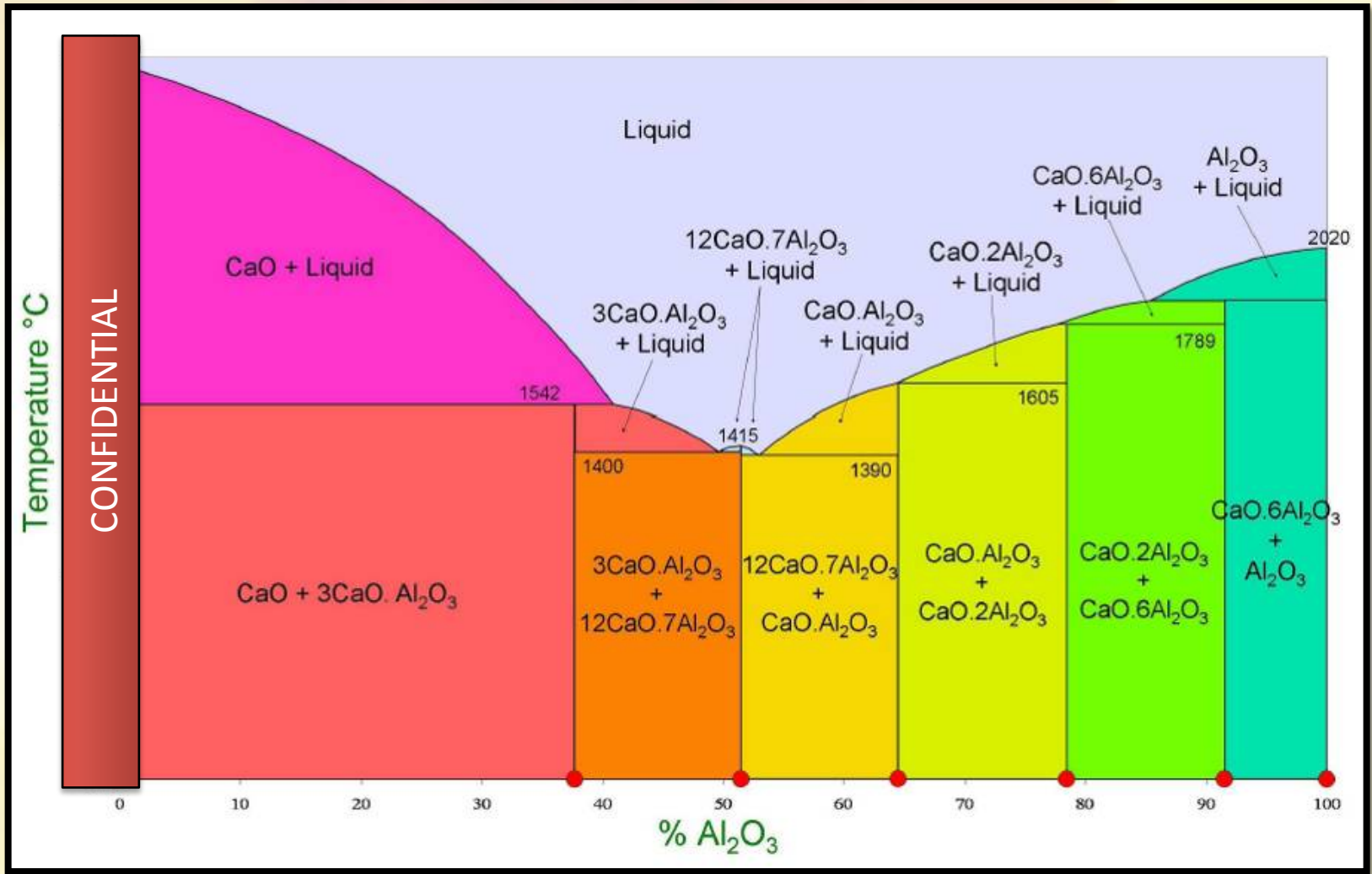

Phase diagram

# PROBLEM 1: RING FORMATION

Higher Air/Gas ratio: 12

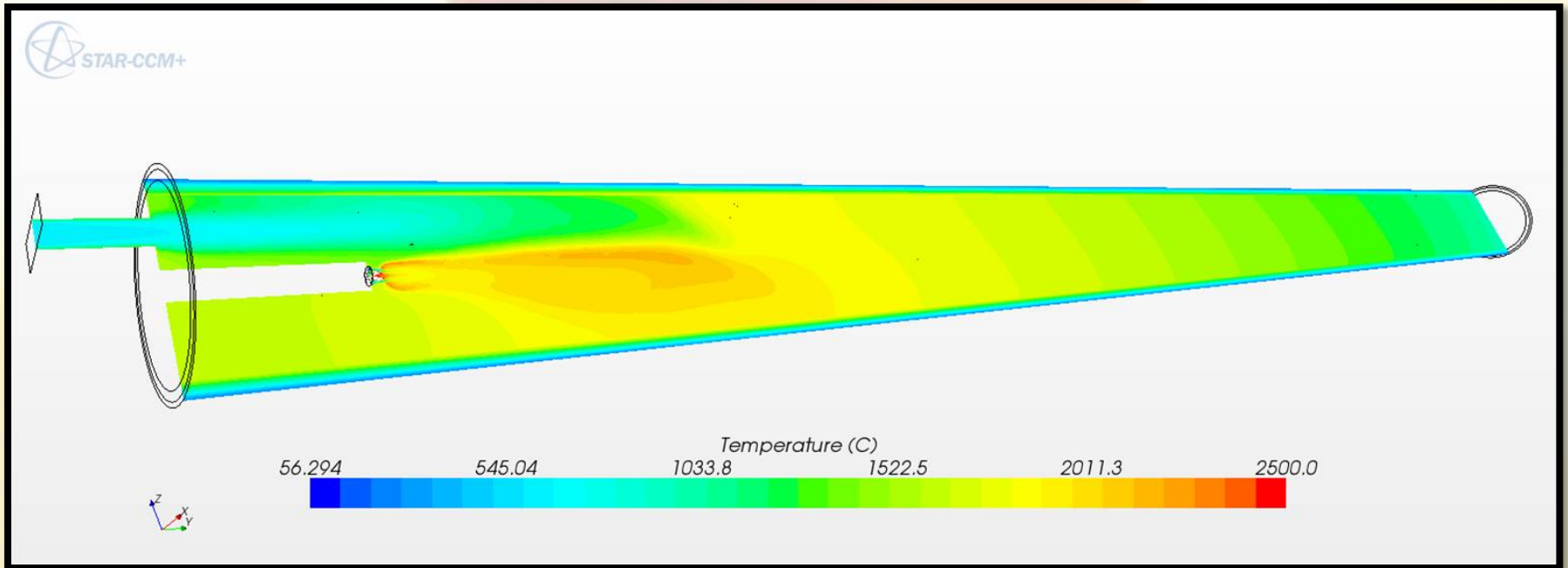

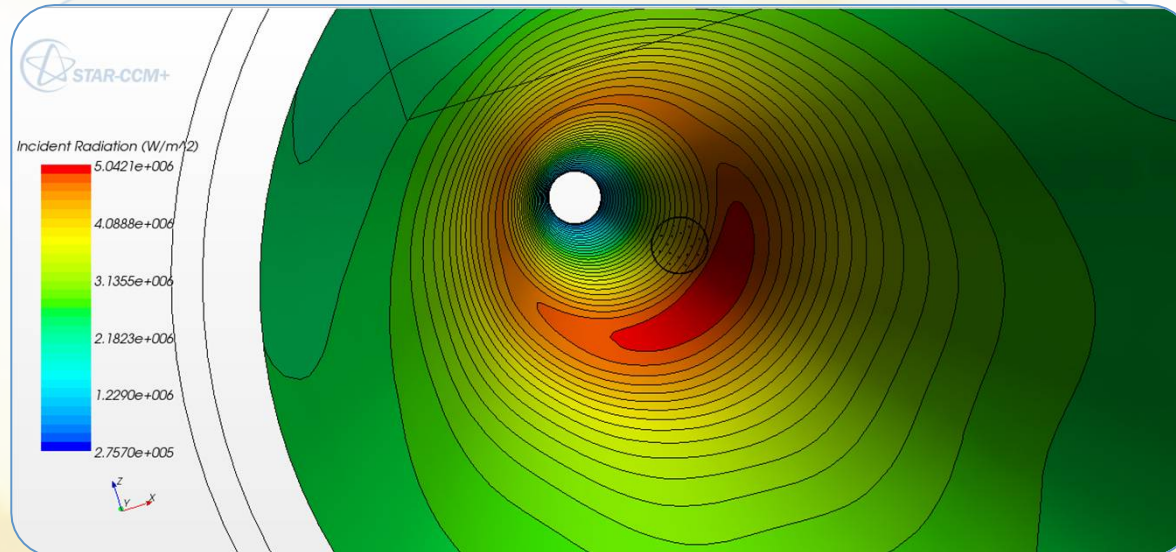
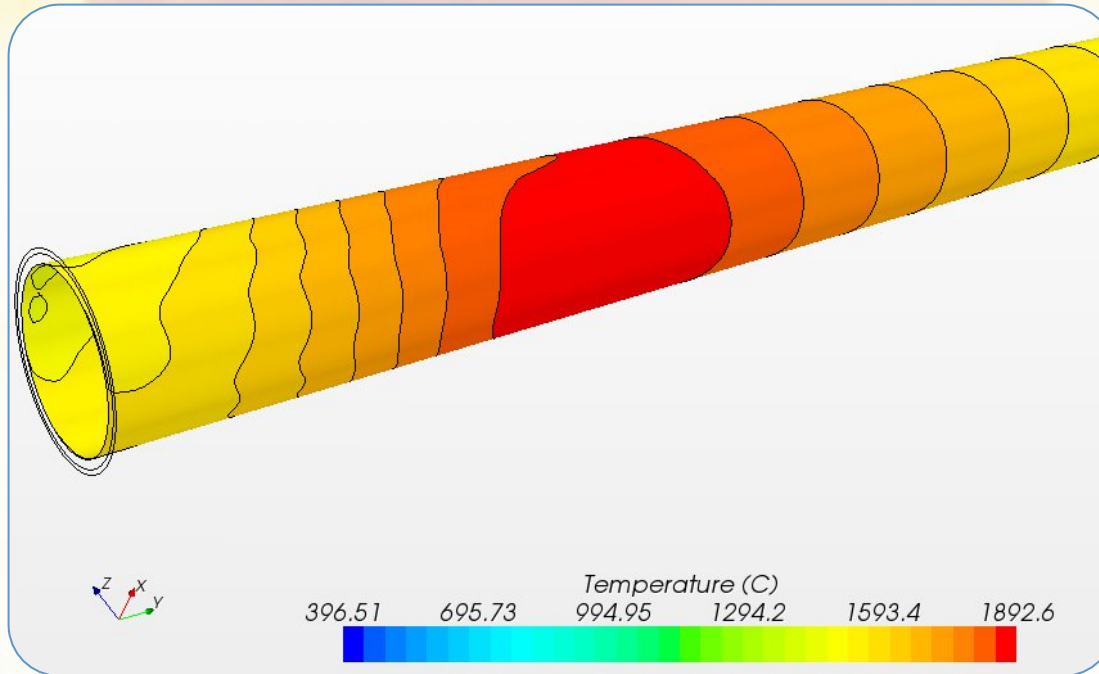

# PROBLEM 1: RING FORMATION, MODEL PREDICTION

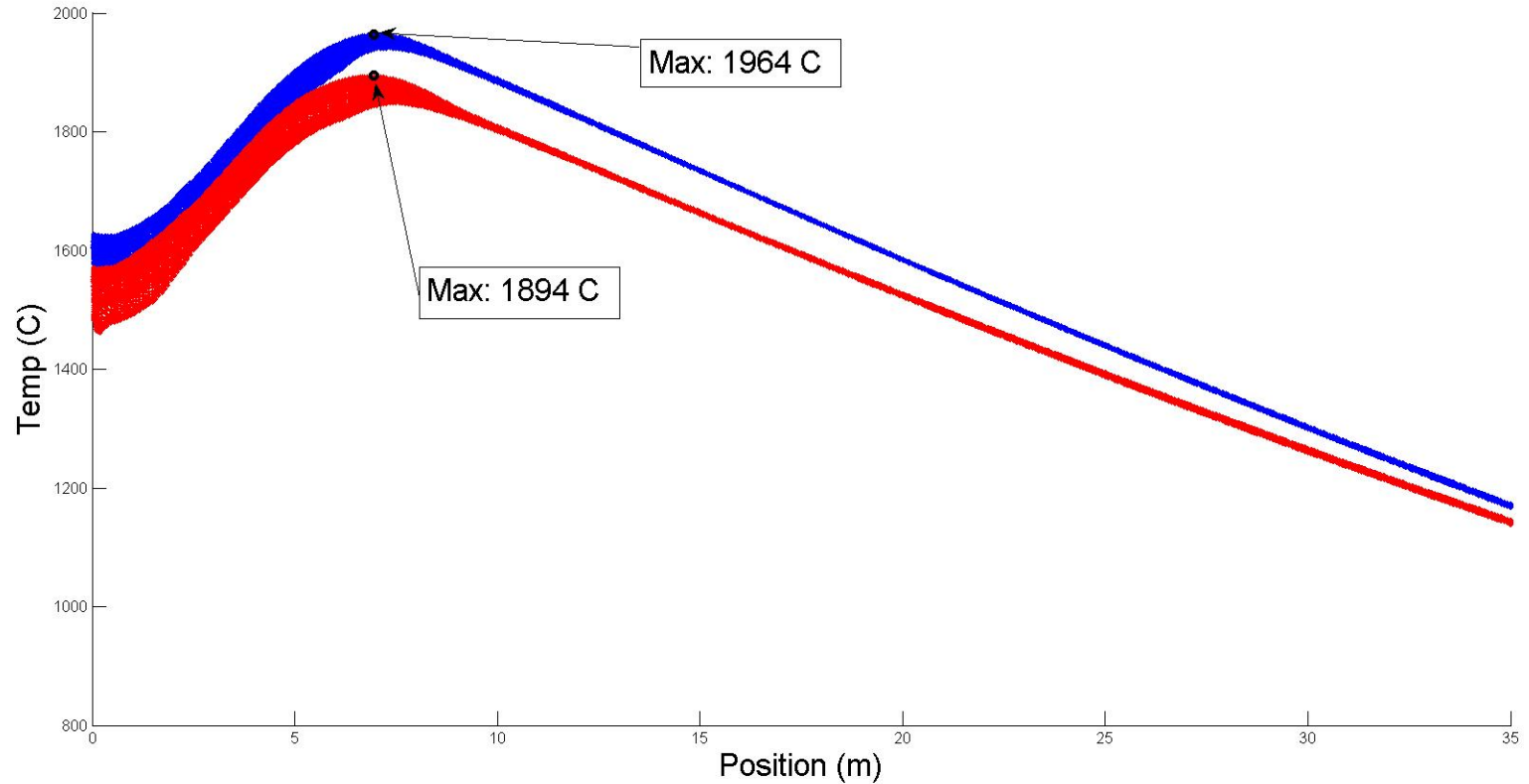

# PROBLEM 1: RING FORMATION, MODEL PREDICTION

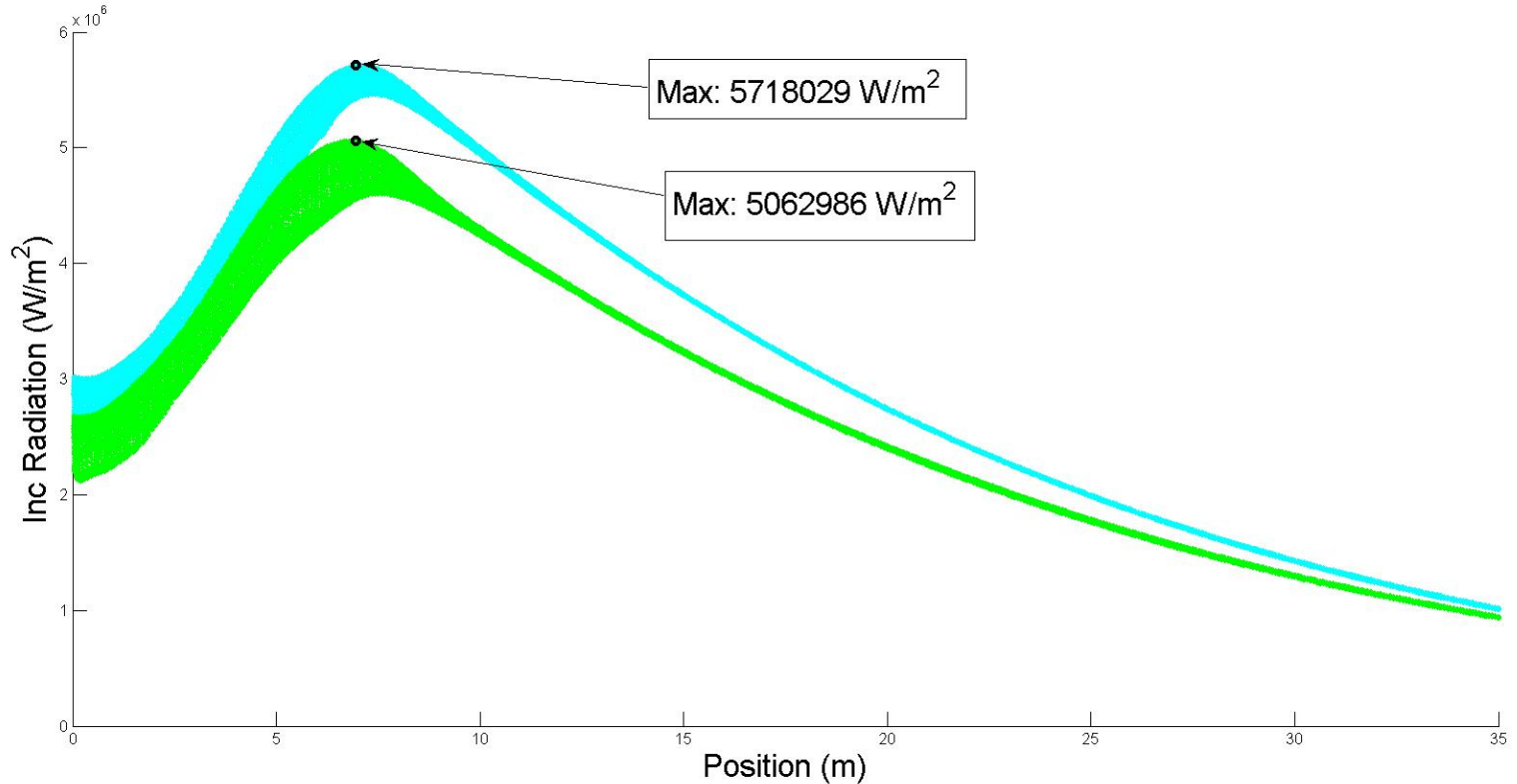

# PROBLEM 1: RING FORMATION, EXP VALIDATION

- On August the 28th 2011, a **severe ring formation** was reported.



# PROBLEM 1: RING FORMATION, EXP VALIDATION

- On August the 28th 2011, a **severe ring formation** was reported.
- It was **decided to increase the A/G ratio** substantially (from 9, to 12). Reducing the flame temperature and heat-transfer via radiation. That will stop the growing of the ring dam.



# PROBLEM 1: RING FORMATION, EXP VALIDATION

- On August the 28th 2011, a **severe ring formation** was reported.
- It was **decided to increase the A/G ratio** substantially (from 9, to 12). Reducing the flame temperature and heat-transfer via radiation. That will stop the growing of the ring dam.
- 4 hours later the **ring stops growing**.





# PROBLEM 1: RING FORMATION, EXP VALIDATION

- On August the 28th 2011, a **severe ring formation** was reported.
- It was **decided to increase the A/G ratio** substantially (from 9, to 12). Reducing the flame temperature and heat-transfer via radiation. That will stop the growing of the ring dam.
- 4 hours later the **ring stops growing**.
- 40 hours later the kiln remain stable in operation.



# PROBLEM 1: RING FORMATION, EXP VALIDATION

- On August the 28th 2011, a **severe ring formation** was reported.
- It was **decided to increase the A/G ratio** substantially (from 9, to 12). Reducing the flame temperature and heat-transfer via radiation. That will stop the growing of the ring dam.
- 4 hours later the **ring stops growing**.
- 40 hours later the kiln remain stable in operation.
- Several days later, the kiln ring deminish slowly until it was almost destroyed.



# PROBLEM 1: RING FORMATION, EXP VALIDATION

- On August the 28th 2011, a **severe ring formation** was reported.
- It was **decided to increase the A/G ratio** substantially (from 9, to 12). Reducing the flame temperature and heat-transfer via radiation. That will stop the growing of the ring dam.
- 4 hours later the **ring stops growing**.
- 40 hours later the kiln remain stable in operation.
- Several days later, the kiln ring deminish slowly until it was almost destroyed.

## ✓ CONCLUSION:

When the growing of the ring is stopped and we reach a temperature at which the liquid phase is very low, the vibration due to the drive gears of the kiln and the rotation gradually breaks **lumps** from the ring and after **40 hours the ring is almost destroyed**.



## ACTIVE RESEARCH THEMES:

- **COMBUSTION OPTIMIZATION → COAXIAL INJECTION**
- **DETAILED MULTICOMPONENT FUEL MECHANISM**
- **LOW-NO<sub>x</sub> BURNERS**
- **DEM/EULER-EULER GRANULAR BED SIMULATIONS (M. ROMERO)**

# CO-AXIAL (SECONDARY) AIR INJECTION

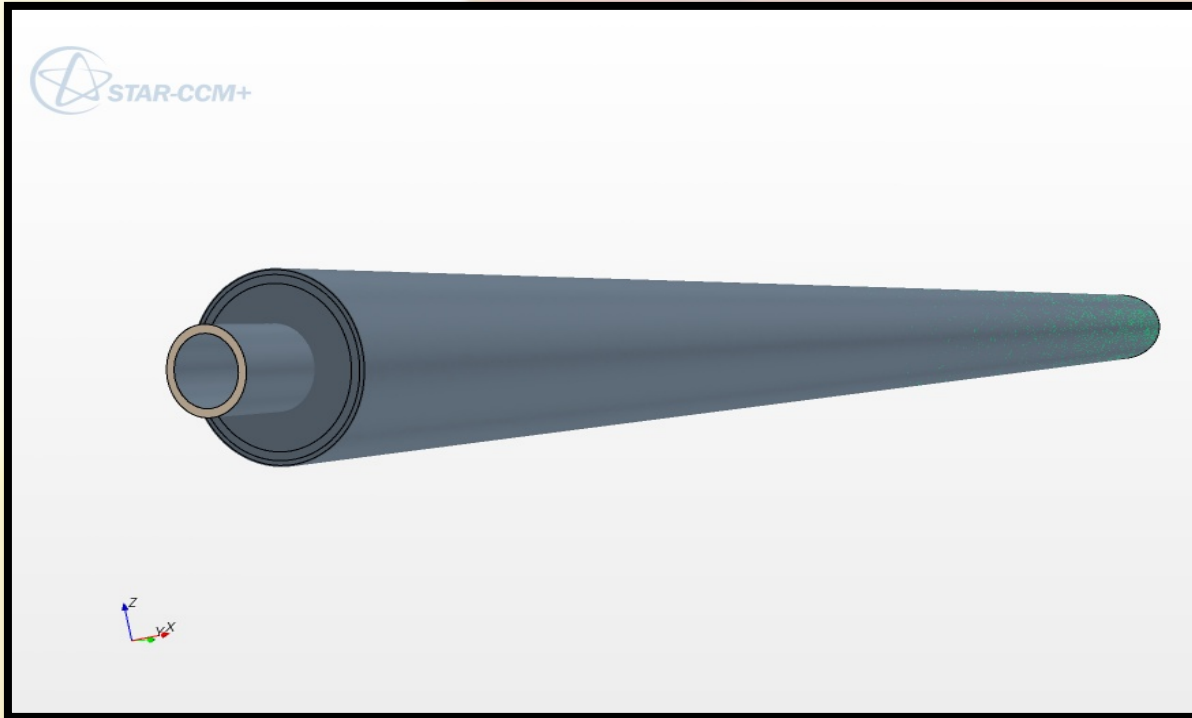

# CO-AXIAL (SECONDARY) AIR INJECTION

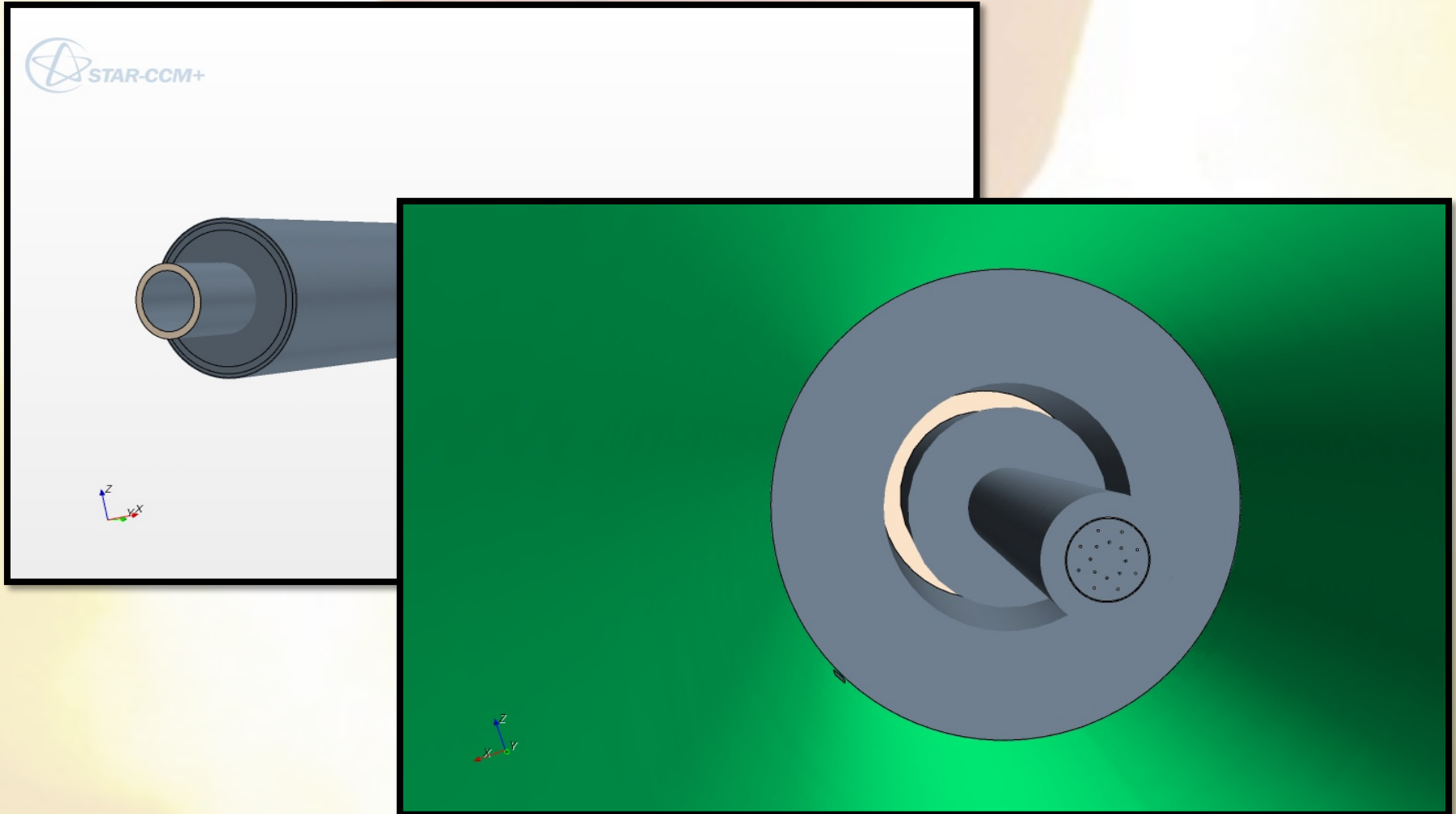

# CO-AXIAL (SECONDARY) AIR INJECTION: TEMPERATURE

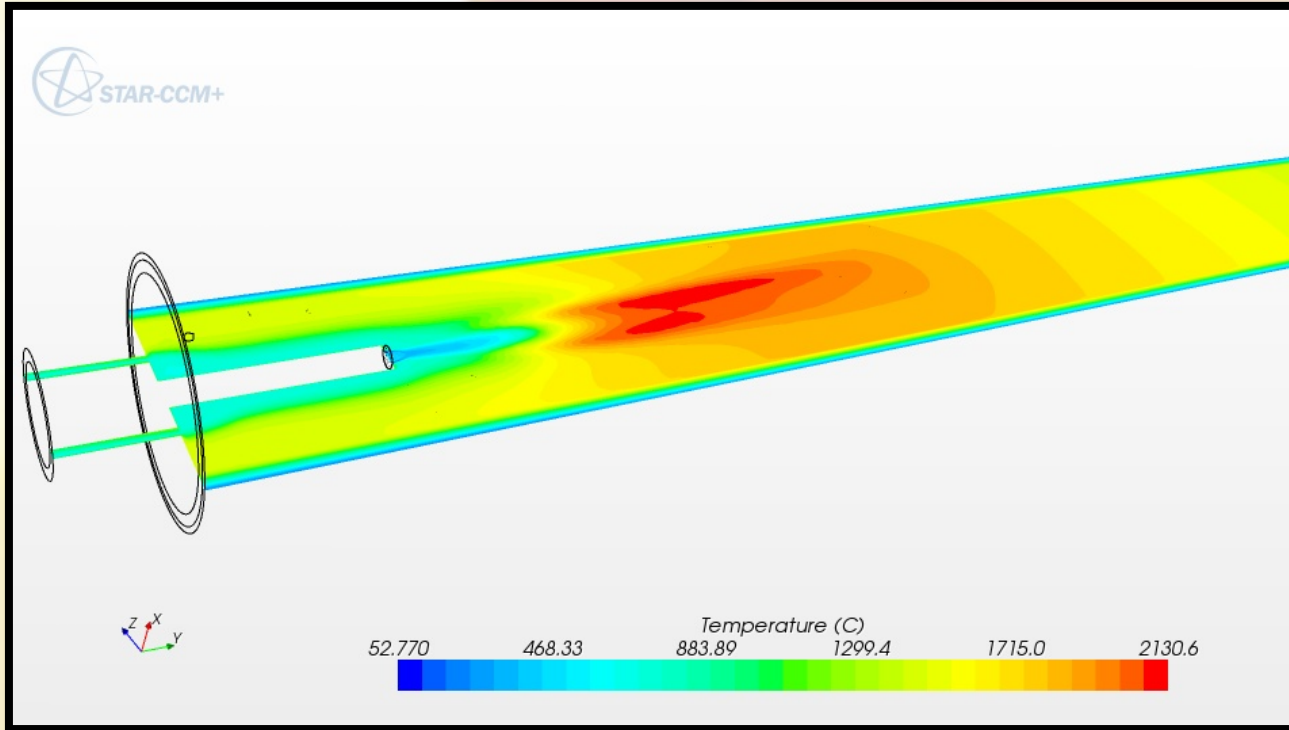

# CO-AXIAL (SECONDARY) AIR INJECTION: TEMPERATURE

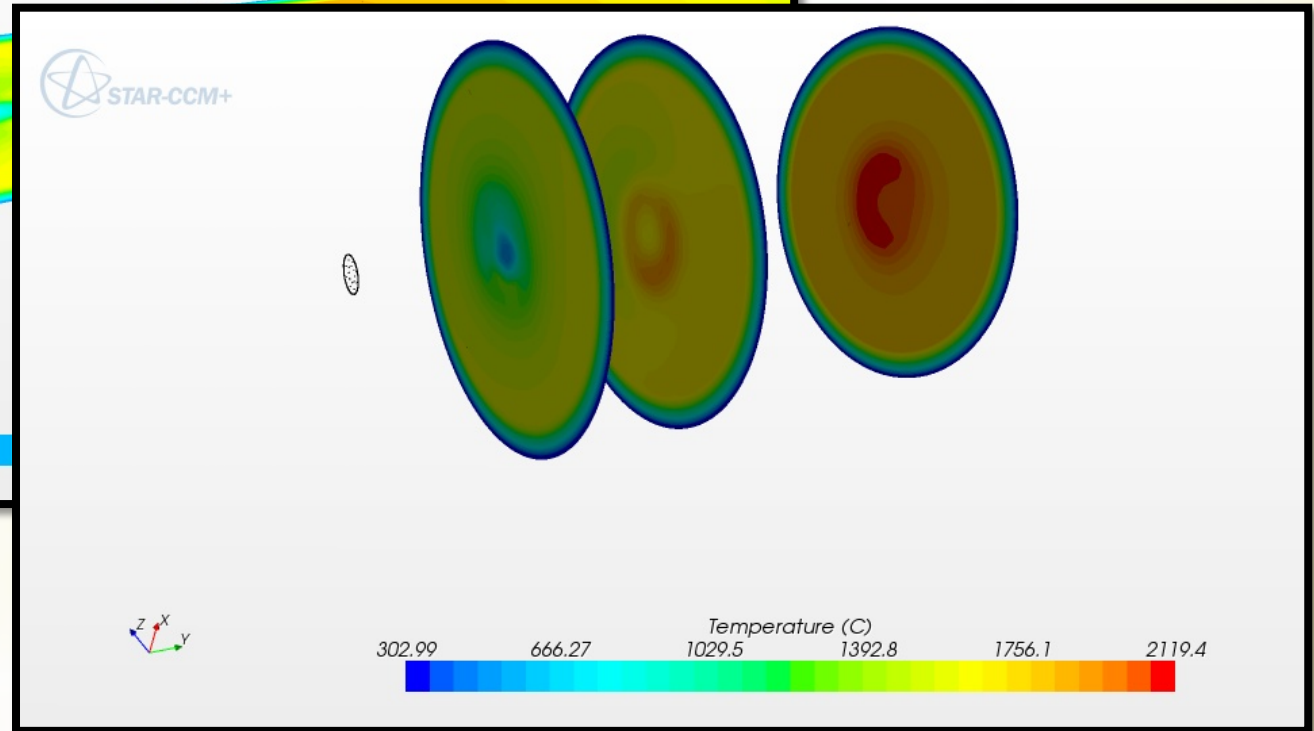
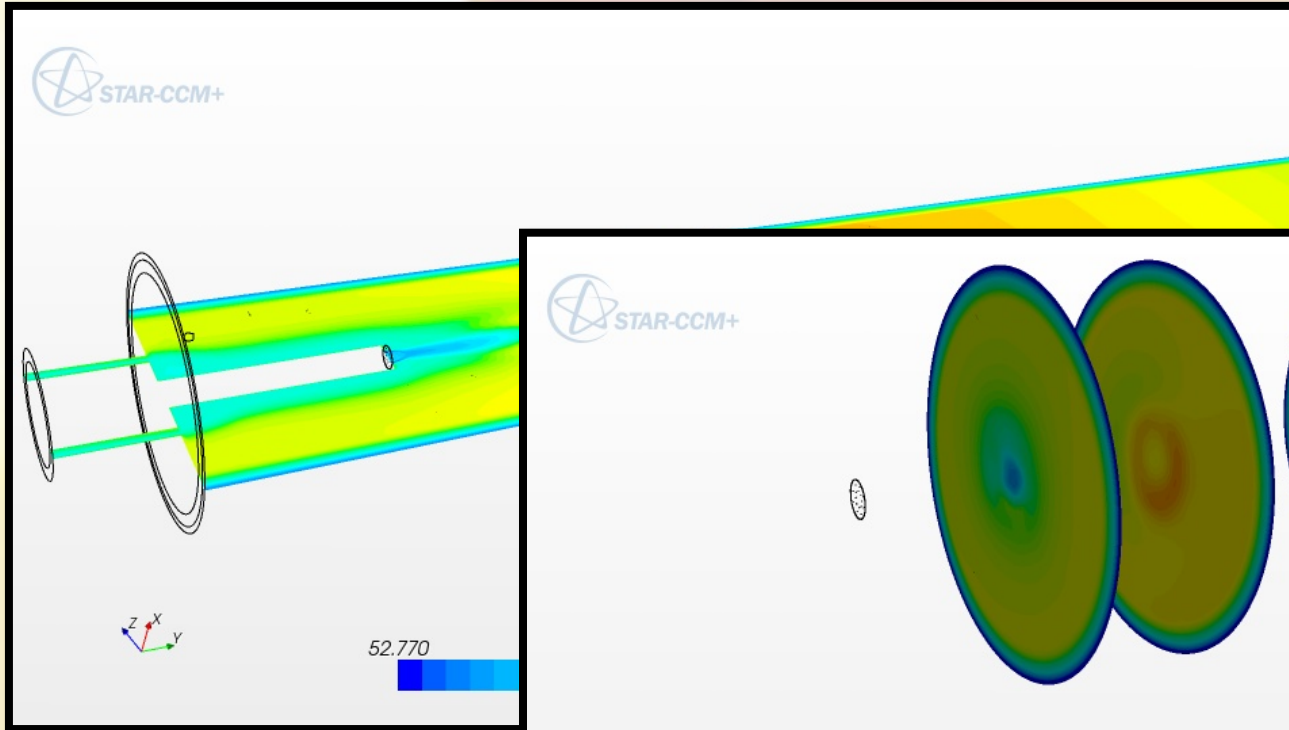



# CO-AXIAL (SECONDARY) AIR INJECTION: O<sub>2</sub> CONCENTRATION

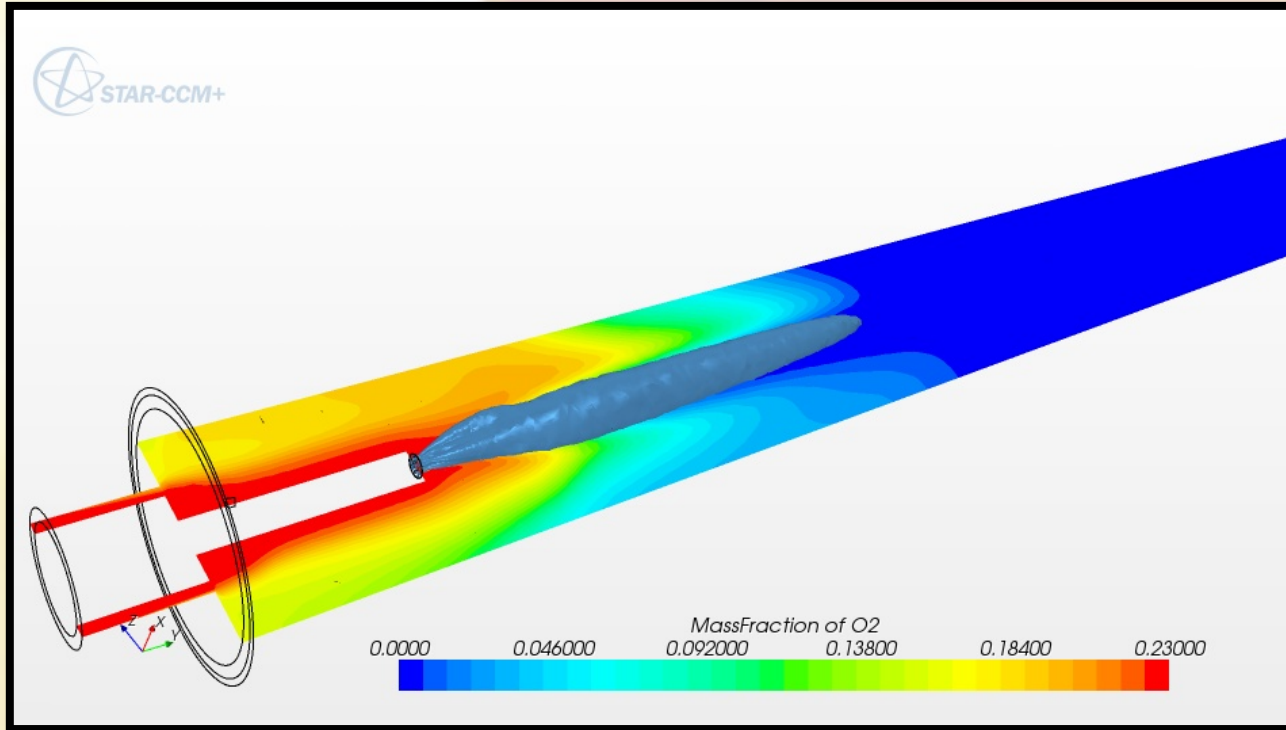

# CO-AXIAL (SECONDARY) AIR INJECTION: O<sub>2</sub> CONCENTRATION

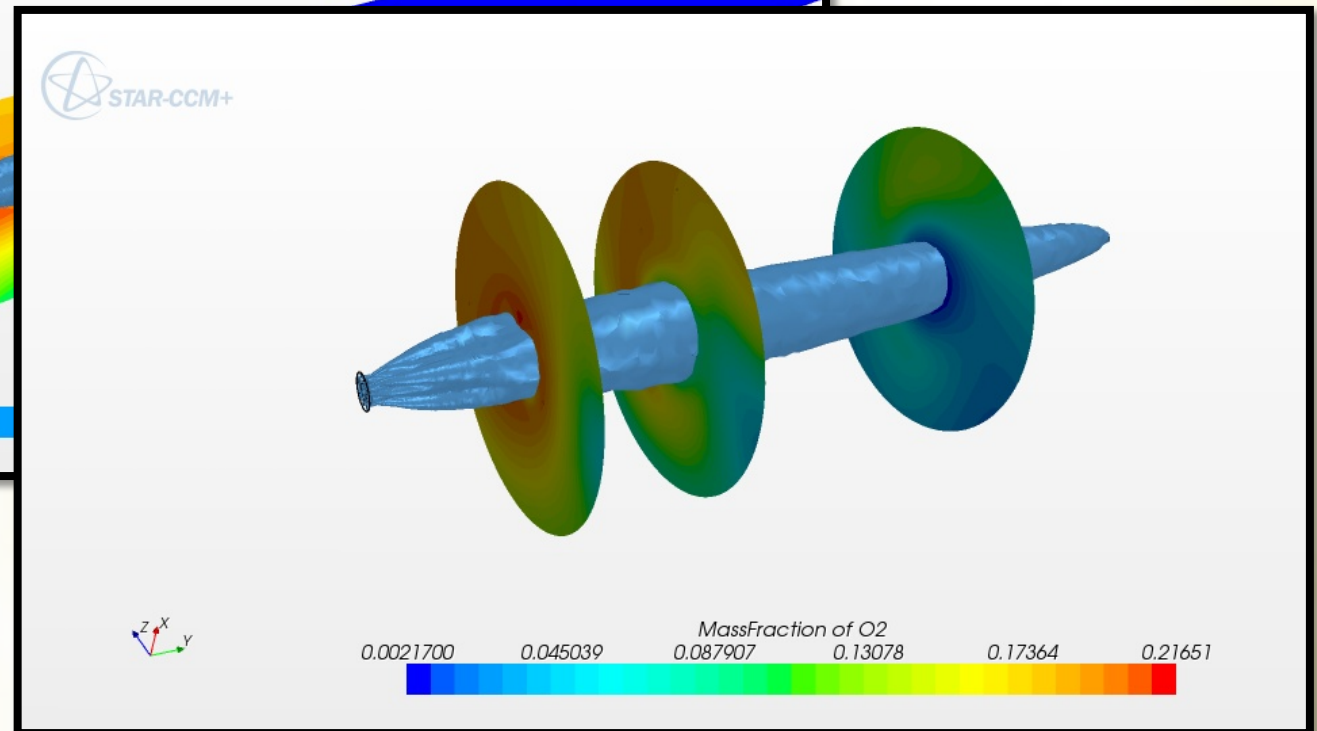
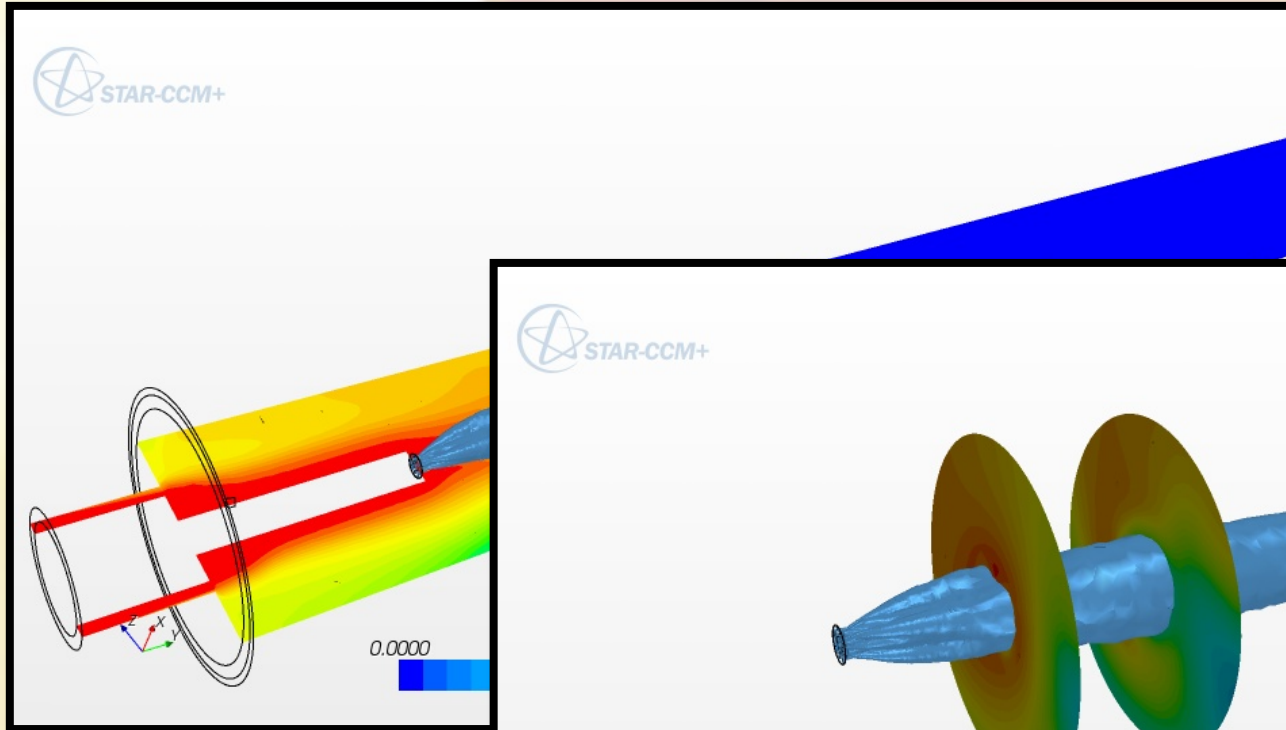

# CO-AXIAL (SECONDARY) AIR INJECTION: WALL

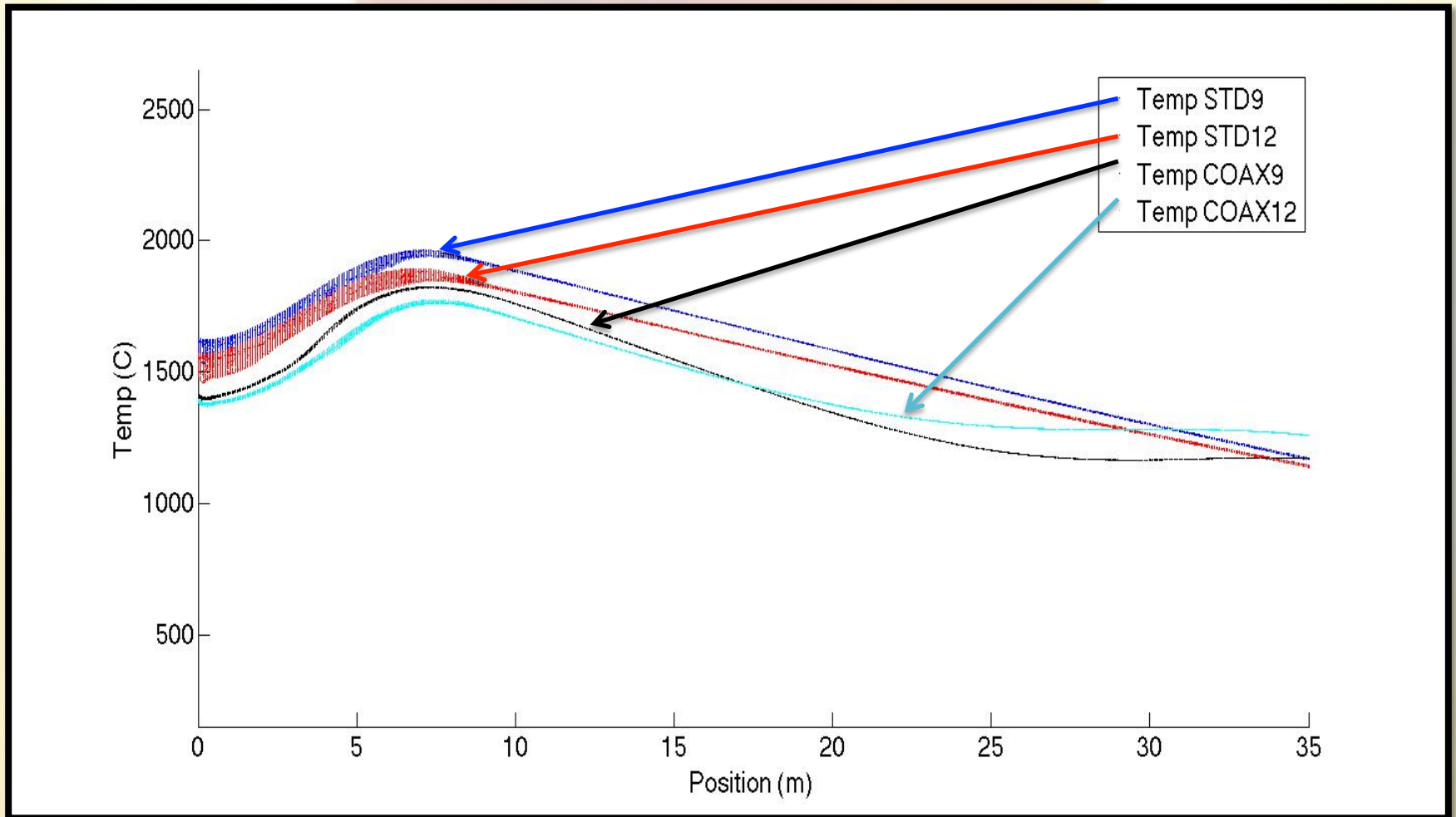

# CO-AXIAL (SECONDARY) AIR INJECTION: WALL

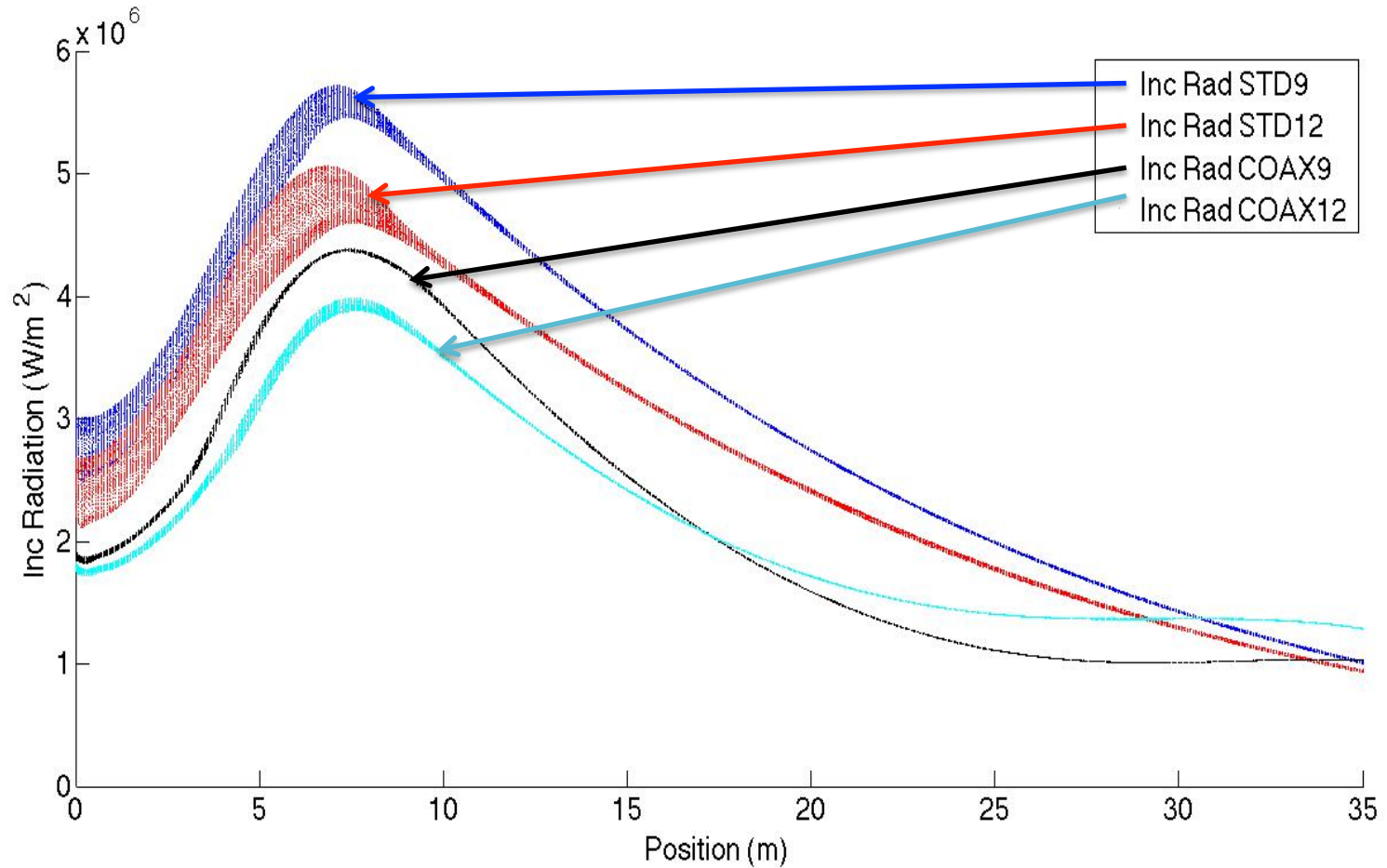

## ACTIVE RESEARCH THEMES:

- **COMBUSTION OPTIMIZATION → COAXIAL INJECTION**
- **DETAILED MULTICOMPONENT FUEL MECHANISM**
- **LOW-NO<sub>x</sub> BURNERS**
- **DEM/EULER-EULER GRANULAR BED SIMULATIONS (M. ROMERO)**

# 1D-GRANULAR BED MODEL

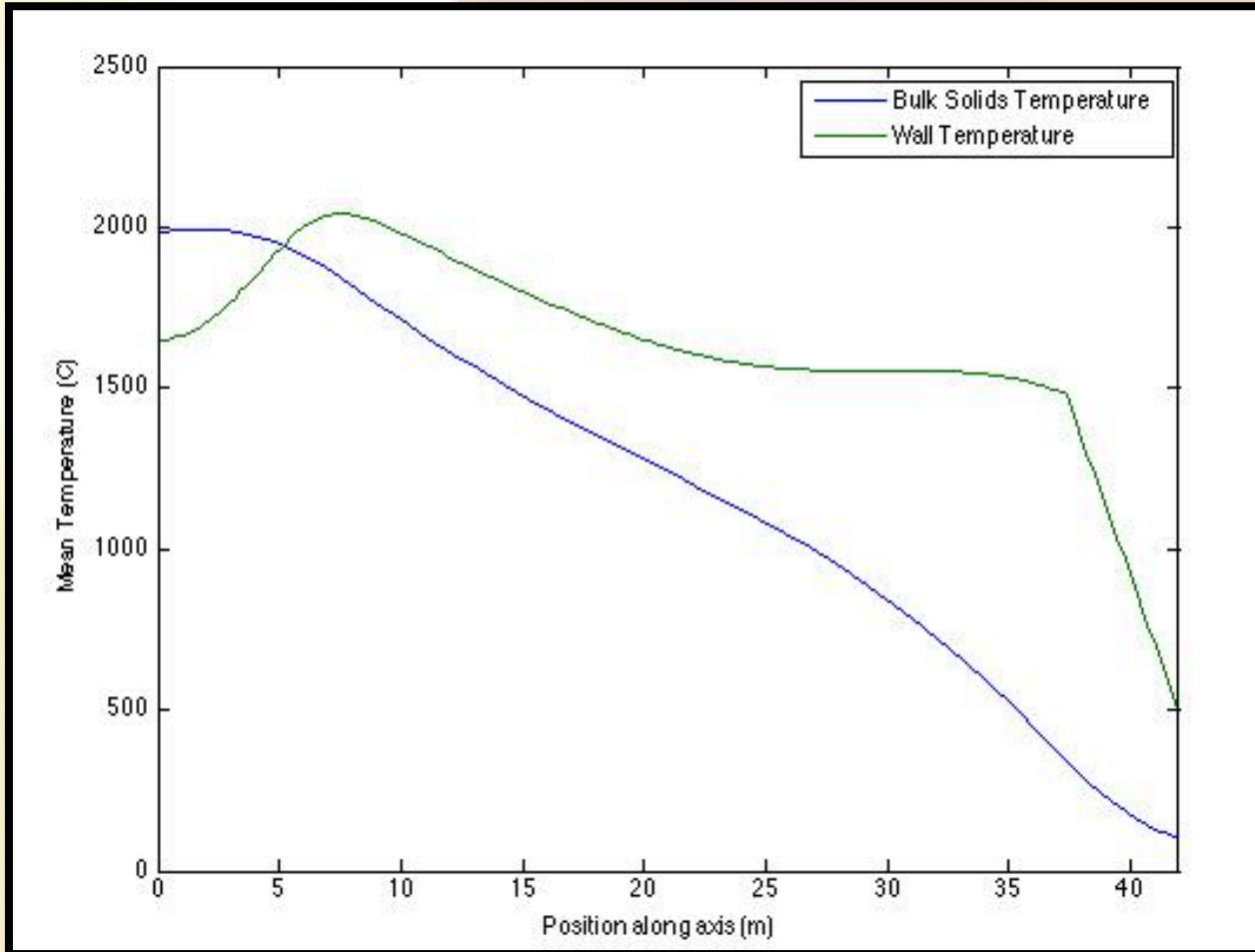

**RESULTS OBTAINED  
BY MIGEL ROMERO**

**THANK YOU FOR YOUR ATTENTION**

**QUESTIONS?**

***THE ONLY DIFFERENCE BETWEEN A PROBLEM AND A SOLUTION IS THAT PEOPLE UNDERSTAND THE SOLUTION.***

***[CHARLES KETTERING]***